

(※本報告書は英語で記述してください。ただし、産業利用課題として採択されている方は日本語で記述していただいても結構です。)

 MLF Experimental Report	提出日 Date of Report 2011/7/14
課題番号 Project No. 2010B0080 実験課題名 Title of experiment Study on muon transfer process in the liquid phase 実験責任者名 Name of principal investigator 篠原 厚 所属 Affiliation 大阪大学	装置責任者 Name of responsible person 三宅 康博 装置名 Name of Instrument/(BL No.) D2 ビームライン 実施日 Date of Experiment 2011/1/24~2011/1/28

試料、実験方法、利用の結果得られた主なデータ、考察、結論等を、記述して下さい。(適宜、図表添付のこと)
 Please report your samples, experimental method and results, discussion and conclusions. Please add figures and tables for better explanation.

1. 試料 Name of sample(s) and chemical formula, or compositions including physical form.
Benzen Cyclohexan Carbon tetrachloride Mixture sample (Cyclohexan + Carbon tetrachloride)

2. 実験方法及び結果 (実験がうまくいかなかった場合、その理由を記述してください。) Experimental method and results. If you failed to conduct experiment as planned, please describe reasons.
<p><u>Experiment method:</u></p> <p>This experiment was performed in D2 muon beam line of J-PARC-Muse. A gas chamber developed by a group of Ninomiya et al. (2010A0048) was used for the muonic X-ray measurements in the experiment. Aluminum sample holders (70 × 60 × 2 mm) filled with sample solution was installed in the gas chamber filled with helium gas. Two germanium detectors were also installed on both sides of the chamber, as shown in Fig.1.</p> <p>First, we determined the conditions of the muon momentum for muons to stop in the sample solution from the variation of the intensity ratio of Aluminum (3-2) and carbon (2-1), and obtained 34MeV/c as the optimal momentum.</p> <p>The samples measured and irradiation conditions are summarized in Table 1. We successfully obtained the muonic X-ray spectra with excellent S/N for a liquid samples, as one can see in Fig.2.</p> <p><u>Preliminary Results:</u></p> <p>Figure 3 shows the muonic X-ray intensity pattern for C₆H₁₂+CCl₄(%) system as an example. We can extract the</p>

2. 実験方法及び結果(つづき) Experimental method and results (continued)

the contribution of external transfer from the precise muonic X-ray spectrum by using a cascade calculation for muonic atoms This analysis is now in progress.

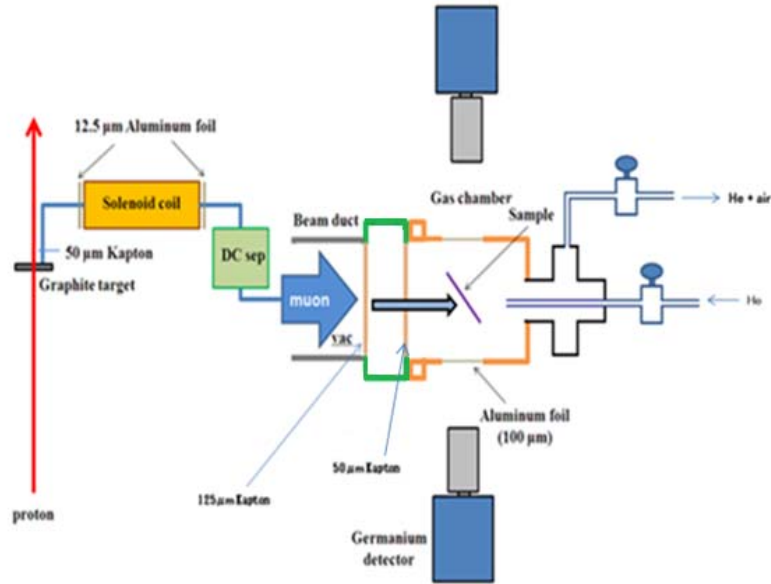

Table1 List of the measured sample

測定サンプル	測定時間
C6H12	8h
C6H6	11h
CCl4	9h
C6H12+CCl4=2:1	17h
C6H12+CCl4=97:3	22h

Fig. 1. Experimental setup installed at D2 beam line.

Fig. 2. Typical muonic X-ray spectrum for mixture sample of C₆H₁₂ and CCl₄.

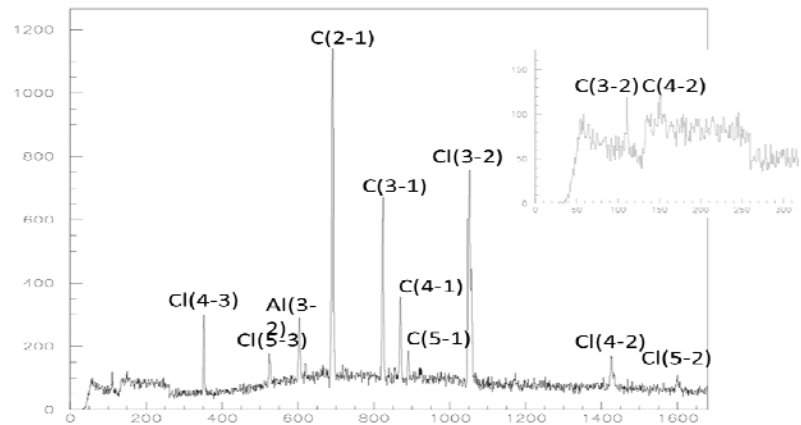

Fig. 3. Comparison of the intensity ratio of muonic X rays

